

CompactPCI is Changing the Economics of Embedded Systems

By now, most designers have heard about CompactPCI (CPCI). A new board technology that is the subject of much conversation, CompactPCI offers features considered essential by those planning a new embedded systems product. But far more important is how CompactPCI's promises to completely change the economics of the industry.

Developed and optimized for industrial applications, CompactPCI relies on the volume economics created by the personal computer industry and the large and growing body of sophisticated applications, development tools, and device drivers to help create more sophisticated, yet less expensive products for expanding markets in telecommunications, industrial control, medicine, and the military.

Before exploring what it is that makes CompactPCI so exciting, first a quick review of CompactPCI's other important features:

- CPCI is offered in a standard form factor, including both 3U (100 mm by 160 mm) and 6U (160 mm by 233) boards, making it an easy replacement for sites requiring Eurocard-based solutions
- CompactPCI uses a 220 pin, 2 mm "hard metric" connector in its basic configuration, with the 6U boards supporting three additional connectors for a total of 315 pins. Optional connectors are set aside for user-defined applications. Common tasks like VME bridging and telephony applications will be able to make use of recommended practice stan-

dards currently under development.

- CompactPCI uses rear-panel connectors - all important for mission-critical applications that require the rapid replacement of boards in order to get back on-line fast.
- Mezzanine-mounted memory and expansion cards offer fewer restrictions to airflow and increase expansion potential
- Unlike PCIbus motherboards, which limit expansion to three or four boards, CompactPCI can accommodate up to eight boards, with additional expansion easily supported through the use of readily available bridge chips.
- The CompactPCI backplane is entirely passive with no active components. As a result, failed boards can be easily replaced.

COMPACTPCI VS. VME - WHO WILL WIN?

Such features certainly make CompactPCI worthy of our attention, but industry insiders understand that any

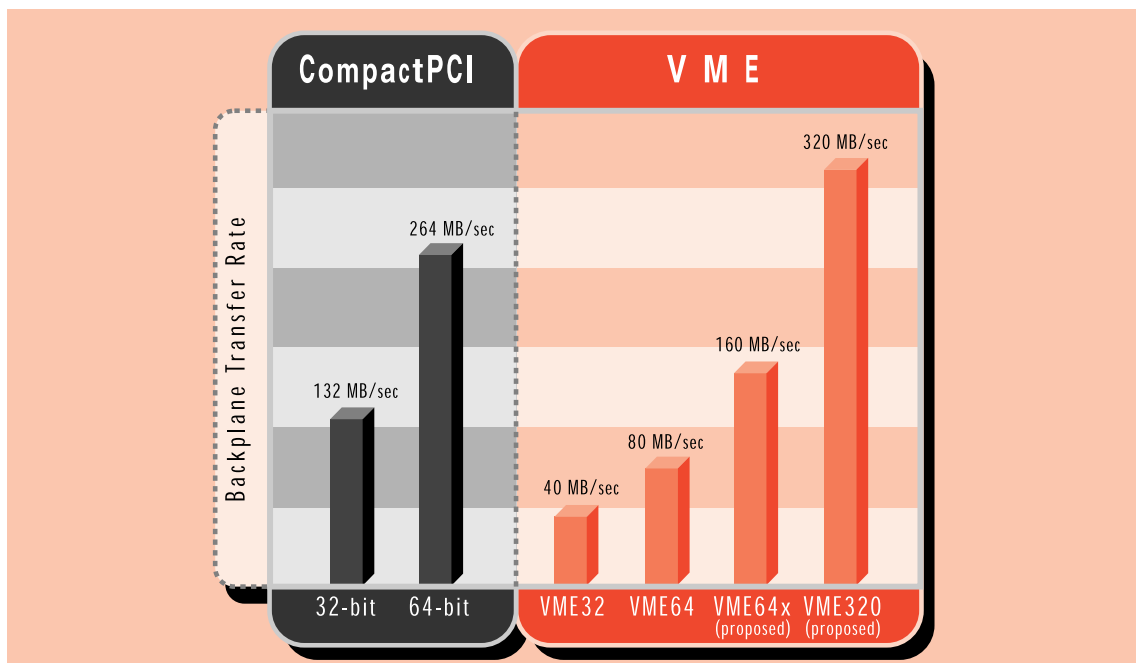

Figure 1. CompactPCI performance overshadows that of all but the most exotic VME technology

COMPACTPCI

new technology must be compared with the current industry leader, VME. Dominating the embedded systems market, VME also supports the Eurocard form factor and up to 21 boards per chassis. Before replacing it with a competing technology, engineers and designers will ultimately ask about performance, and managers will want to know how changing will help them create better products more quickly and for less money.

CompactPCI is fast. At 132 MB/sec. in 32-bit systems and 266 MB/sec. When configured in 64-bit mode, CompactPCI easily tops VME's 32-bit 40 MB/sec and 64-bit 80 MB/sec. Not standing still, VME configurations are emerging that boost its performance (Figure 1). In some cases, like VME64X, backwards compatibility would be compromised, while other specifications, like VME320, would allow data rates up to 320 Mbytes/sec and still offer backwards compatibility to slower systems. (VME320 is not without its detractors though - some believe that it represents a complex answer to the simple, straightforward technology of CompactPCI.)

Despite its performance superiority over VME, CompactPCI's biggest advantage is found in bottom-line business issues - economics, time-to-market, and product quality.

Worldwide, companies are struggling to compete through more aggressive pricing strategies, faster time-to-market, and improved products. To reduce the development time of products which include sophisticated software components, engineering teams are adopting rapid application development (RAD) techniques, programming environments that offer improved design and debugging tools, and entirely

new programming languages like Java. Unfortunately many of these innovations come late to those developing for embedded systems. Because embedded systems represent a small segment of the computer market as a whole, and because it employs specialized technologies like VME, developers in this arena haven't had access to many of the advantages enjoyed by the broader marketplace.

Despite this, the growth of global competition in the last decade has produced users that are demanding products that are more economical, effortless to upgrade, and easy to maintain - all characteristics more in step with those found in current enterprise-class workstation and server systems. This leaves managers and embedded systems designers questioning how they are expected to respond to the delays traditionally experienced in adapting new technologies to embedded systems.

Another factor driving the market is the accelerating trend of building mission-critical applications using embedded systems products. Such applications require higher levels of performance and scalability along with reliability and robustness. One rapidly growing industry with this issue is comprised of firms providing Internet service. Sun Microsystems has defined the idea of the "Webtone" - extending to the Internet the idea of the traditionally reliable telephone system where users can count on always obtaining a dialtone. Once Webtone quality service is more ubiquitous, users will come to rely on the Internet and the Web much like they rely on telephones today. Ensuring such reliable service will place more far sophisticated demands on the technology used to provide Internet-based services.

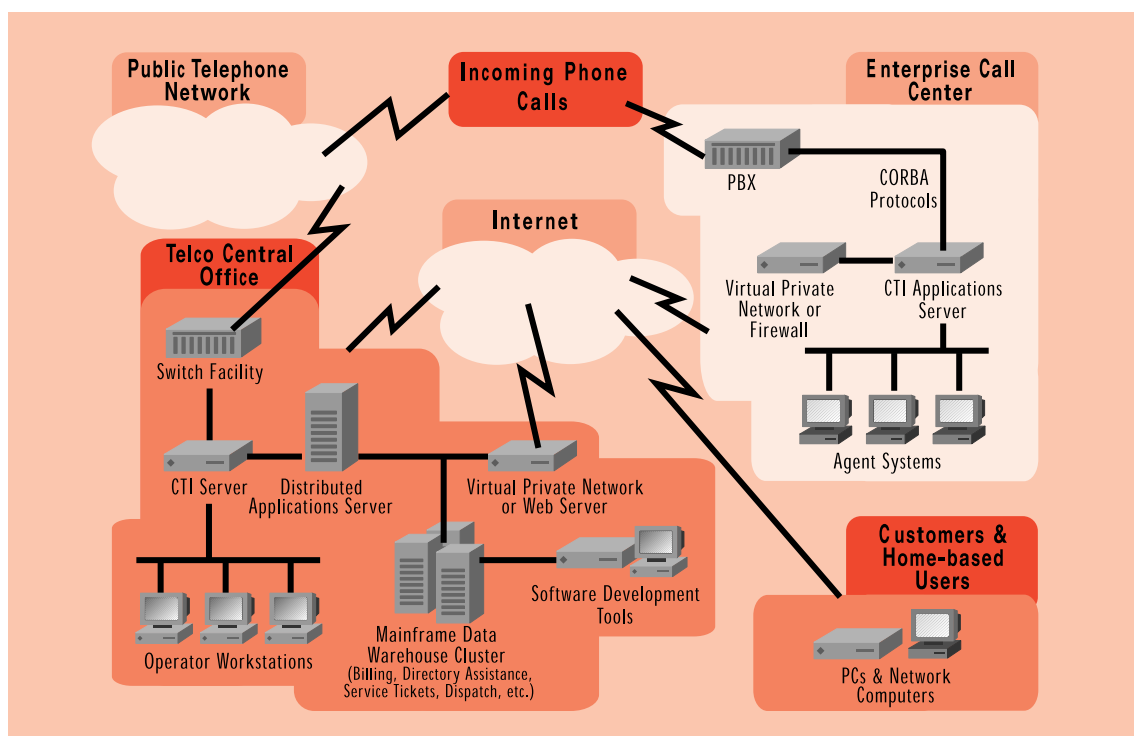

Figure 2. Access to PCI technology will allow telecommunications companies' easier access to products with which to build more sophisticated and powerful solutions.

Ad SBS GreenSpring

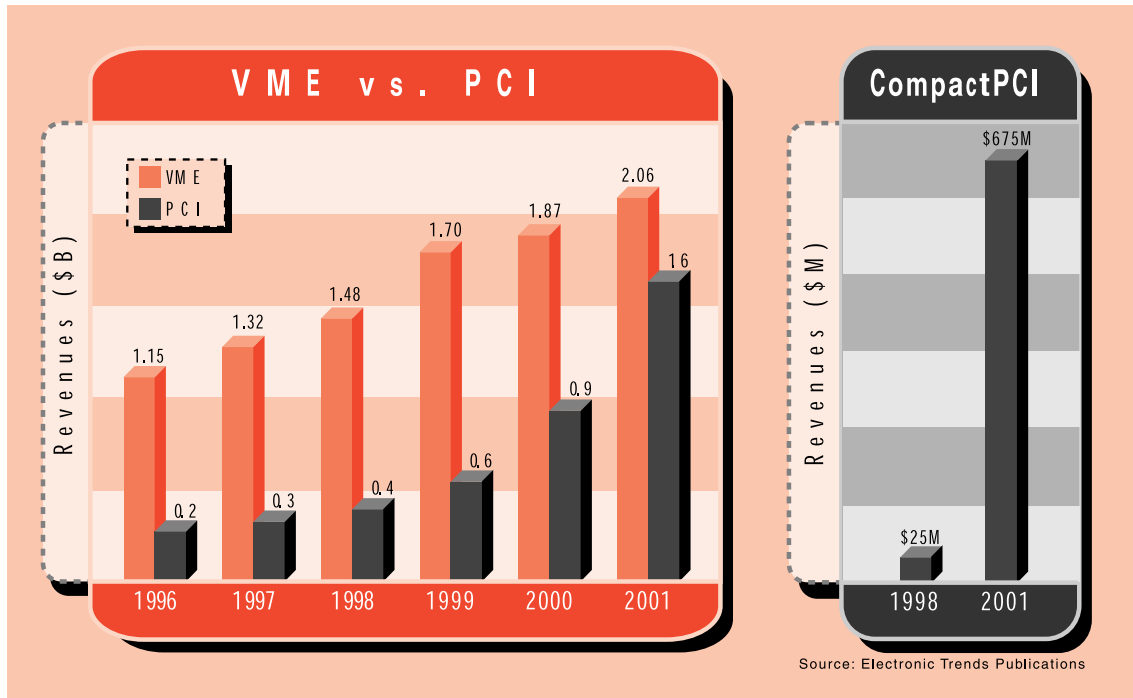

Figure 3. Industry experts like Electronics Trends Publications predict that the effect of PCI technology on the industry will be great. Areas like telecommunications are especially well positioned to profit.

What do these trends have to do with CompactPCI? Consider that PCI-based products are found everywhere in personal computers and workstations. Because CompactPCI uses the same technology - chipsets, device drivers, peripheral interfaces, and applications - used on millions of systems, it automatically benefits from 1) the economies of scale created by the broader PCI industry, 2) quality born of large numbers of released and field-tested products that have demonstrated their reliability, 3) the immediate access to a huge body of mature technology, and 4) access to some of the most advanced and highly refined development tools in the industry. All of this adds up to a huge advantage for firms considering the development of new products based on the CompactPCI standard.

COMPACTPCI STANDS READY TO TRANSFORM MARKETS

Let's explore in more detail just one example of how CompactPCI might revolutionize markets. The telecommunications industry is going through its biggest changes since the invention of the telephone itself. Freed from regulation and faced with increased global competition, telcos are busy reengineering themselves to thrive in a rapidly changing marketplace that is better equipped to quickly roll out new services.

Quickly deploying new services means creating a hardware and software infrastructure with some impressive capabilities. Equipment must be flexible, easy to maintain, and easy to upgrade. Establishing standards for Central Office deployment mean that traditional form factors defined by NEBS and ETSI standards are maintained. On top of this, established vendors of local and long distance services are finding competition is coming from vendors who formally con-

centrated on offering data communications services - competition that not only have the financial resources to compete, but who are also coming from a technology base that is better positioned to offer services better integrated with the Internet and World Wide Web.

To compete, telcos know that conventional development cycles are far too long - better leverage of existing products as well as the use of RAD methodologies and tools are a necessity. Software products with strong networking and administration capabilities will have to be bought or developed, and new, more reliable designs that incorporate techniques like clustering will need to be adopted. The prospect of developing all of these technologies for VME is a withering thought to most managers. Fortunately, CompactPCI offers a solid, long-term solution to their problem.

Imagine for a moment the effect on the telco marketplace if the products of a company like Sun were available for use in developing advanced, embedded telecommunications products. Developers would have access to a broad palette of high performance workstations and servers, advanced storage architectures, sophisticated development tools, proven operating systems, comprehensive network and systems management products, and powerful clustering tools (Figure 2). The list doesn't stop there - consider also the ease with which third-party products like database management systems could be integrated to assemble the most sophisticated solutions. With CompactPCI, such technology sits right around the corner, simply waiting to be adapted for use in embedded systems products.

Industry observers are not blind to the huge potential of CompactPCI. Electronic Trend publications reports that the revenue of PCI technology as a whole will

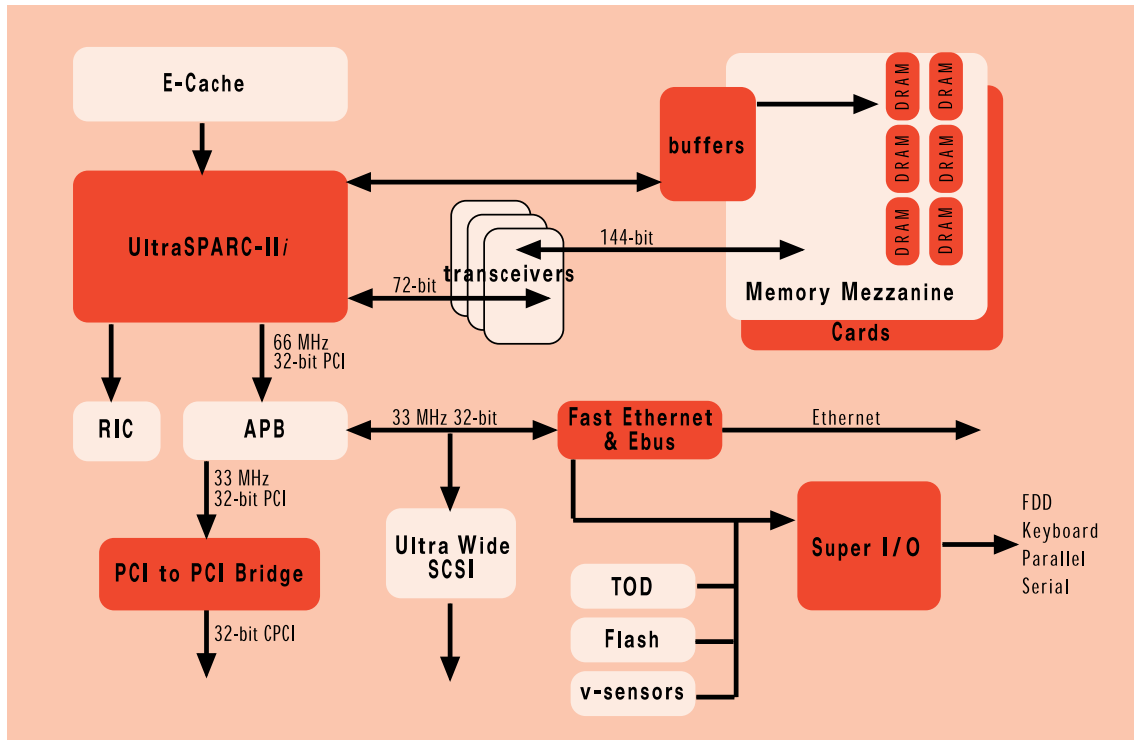

Figure 4. Sun's new SPARCengine CP 1500 is a complete workstation on a single CompactPCI-compatible, 6U form-factor board.

surge from 21% of VME's \$1.15 billion in 1996 to 81% of VME's \$2.06 billion projected revenue in 2001. They go on to state that the effect of CompactPCI on the telecommunications market will be even more profound, with CPCI revenue jumping 27 times from about \$25 million in 1998 to nearly \$675 million in 2001! (Figure 3)

SUN MICROSYSTEMS WILL BE A DRIVING FORCE

Of course, we have spoken here about leveraging technology from other markets into embedded systems as though it can be done today - which fortunately it can. Indeed, Sun Microsystems is well positioned to be to CompactPCI what Motorola has been to VME. Nearly two years ago, Sun

Microsystems, long the dominant vendor of workstations and more recently a powerhouse in enterprise server systems, announced that they would support PCI in all of their new products. Today, all new Sun systems employ PCI, allowing their many board and chipset designs, as well as their extensive array of development tools, diagnostics, low level drivers, enterprise management applications, and even Solaris to be used in embedded systems products based on CompactPCI.

Not merely a theoretical issue, Sun has also introduced the first of a series of board-level products based on the CompactPCI standard.

Implemented on 6U form-factor CompactPCI boards, both the SPARCengine CP 1200 and CP 1500 are full workstations, complete with Ethernet and SCSI interfaces, support for keyboards, mice and serial ports, and capable of running Solaris, one of the most popular

implementations of UNIX in the world. Powered by Sun's popular 270 MHz UltraSPARC lii processor, the CP 1500 is designed to support mission critical applications that also demand high levels of performance and integration (Figure 4). The CP 1200, powered by a highly integrated 100 MHz microSPARCep also offers high levels of price performance, but in a more cost sensitive design for volume deployments.

For applications that require the highest levels of response for real-time control and interrupt processing, Sun's CompactPCI boards are completely compatible with popular real-time operating systems like Sun's Chorus or Wind River Systems VxWorks. When paired with Object Request Broker (ORB) technology, these real-time systems can establish a transparent link to other boards or systems running Solaris, making it possible to craft extremely sophisticated and powerful solutions.

Sun's ability to seed the CompactPCI industry with other important technology doesn't stop with processor boards and Solaris. Sun has an extensive line of networking and peripheral interface cards, enterprise-class network management tools, systems administration applications, and software products to create secure, highly reliable, and powerful application and network servers, data warehouses, and compute farms. With access to such technology, the future promises to be bright for companies ready to develop the next generation of CompactPCI-based embedded systems products. ■

Ellen MacDermid is a Campaigns Manager in the Communications Market division of Sun Microsystems.